

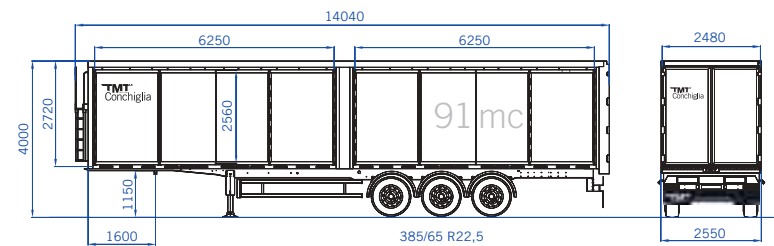

Light

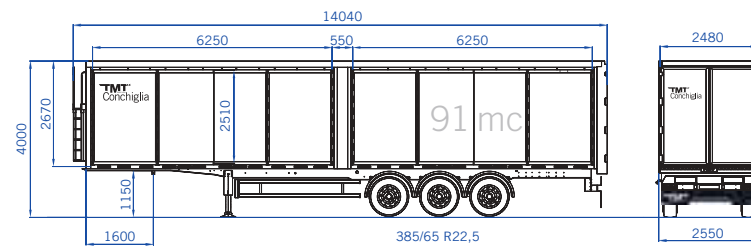

Heavy

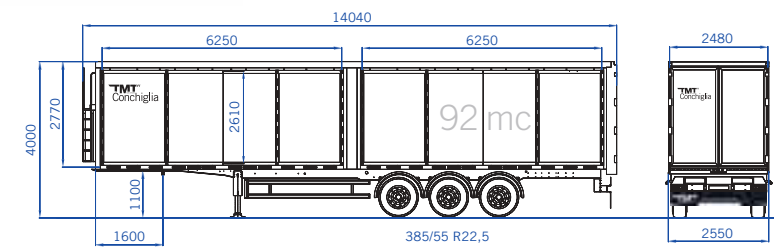
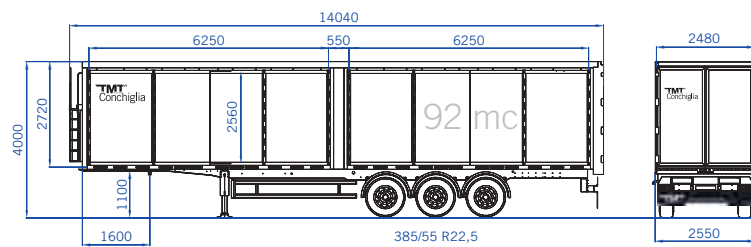

Light

Heavy

Scigno MF

Semirimorchi / Moving floor

___ **Utilizzo:** ✓ Rifiuti ✓ Raccolta e conferimento CDR ✓ Plastica ✓ Carta (sia sfusi che imballati) ✓ Umido ✓ Indifferenziata ✓ Agricolo ✓ Forestale ✓ Riciclaggio ✓ Segatura ✓ Cippato ✓ Cereali ✓ Big Bag ✓ Fieno ✓ Foraggi ✓ Tuberi ✓ Carico e Scarico Colli ✓ Corpi Indivisibili ✓ Pallet ✓ Cassoni ✓ Pannelli ✓ Profilati ✓ 33 europallet

___ **Use:** ✓ Waste ✓ Collection and transfer RDF ✓ Plastic ✓ Paper (both loose and packed) ✓ Wet ✓ Undifferentiated ✓ Agricultural ✓ Forestry ✓ Recycling ✓ Sawdust ✓ Woodchips ✓ Cereals ✓ Big Bag ✓ Hay ✓ Fodder ✓ Tubers ✓ Loading and Unloading Packages ✓ Bodies Indivisible ✓ Pallets ✓ Boxes ✓ Panels ✓ Profiles ✓ 33 europallet

___ **Utilisation:** ✓ Déchets ✓ Collecte et livraison des CDD ✓ Plastique ✓ Papier (en vrac et emballés) ✓ Humide ✓ Non différencié ✓ Agricole ✓ Forestier ✓ Recyclage ✓ Sciure ✓ Copeaux de bois ✓ Céréales ✓ Big Bag ✓ Foin ✓ Fourrage ✓ Tubercules- Chargement et déchargement de colis ✓ Corps indivisibles ✓ Palettes ✓ Caissons ✓ Panneaux ✓ Profilés ✓ 33 europalettes

___ **Gebrauch:** ✓ Abfälle ✓ Sammlung und Übertragung KAA ✓ Plastik ✓ Papier (unverpackt oder verschnürt) Biomüll ✓ Restmüll ✓ landwirtschaftlicher Abfall ✓ Waldabfälle ✓ Recycling ✓ Sägespäne ✓ Holzschnitzel ✓ Korn ✓ Big Bag ✓ Heu ✓ Grünfutter ✓ Knollenfrüchte ✓ Laden- und Entladen von Packstücken- unteilbare Gegenstände ✓ Paletten ✓ Kasten ✓ Platten ✓ Profile ✓ 33 Europaletten



Scigno E110

Weight (kg)	8800
Chassis and load-bearing structure	Continuous steel chassis. Side doors opening 12,3
Total weight (kg)	40000 / 45000
Suspensions	Air Suspensions with HALDEX, WABCO tridem SAF, ROR, JOST, BPW
Moving floor system	Cargo Floor® System
Floor	21 or 24 alu profiles 6-8-10 mm
Walls	30 mm aluminium extruded profiles

TMT®

Tanks & Trailers

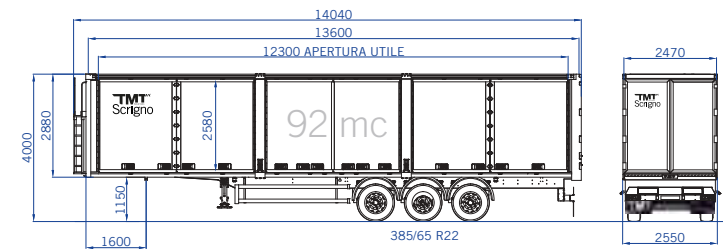
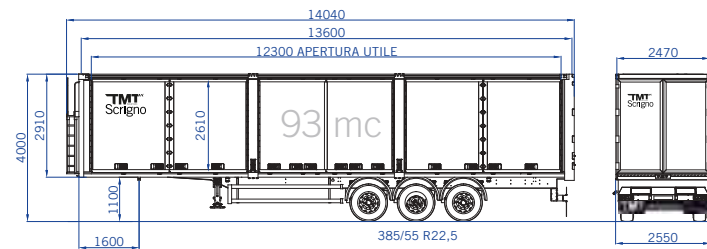

Conchiglia Frigo MF

Semirimorchi / Moving floor

È stato pensato e realizzato specificatamente per trasportare, con l'utilità del piano mobile, merci alimentari sfuse e/o pallettizzate a temperatura controllata e non.

___ **Utilizzo:** ✓ Frutta ✓ Verdura
✓ 33 europallet

It was designed and built specifically to transport loose and / or palletized food goods with controlled temperature and not, with the use of the moving floor.

___ **Use:** ✓ Fruit ✓ Vegetables
✓ 33 europallet

Elle a été conçue et construite spécifiquement pour le transport, avec l'utilité du fond mouvant, de produits alimentaires en vrac et/ou palettisés à température contrôlée ou non.

___ **Utilisation:** ✓ Fruits
✓ Légumes ✓ 33 europalettes

Er wurde speziell dazu entwickelt und verwirklicht, um mit Hilfe der beweglichen Ladefläche, unverpackte Lebensmittel und/ oder auf Paletten bei kontrollierter Temperatur oder auch nicht zu transportieren.

___ **Gebrauch:** ✓ Obst ✓ Gemüse
✓ 33 Europaletten



Conchiglia Frigo

Weight (kg)	9500
Chassis and load-bearing structure	Continuous steel chassis, aluminium box bolted to the frame
Total weight (kg)	40000 / 45000
Suspensions	Air Suspensions with HALDEX, WABCO tridem SAF, ROR, JOST, BPW
Moving floor system	Cargo Floor® System
Floor	21 or 24 alu profiles 6-8-10 mm
Walls	30 mm aluminium extruded profiles

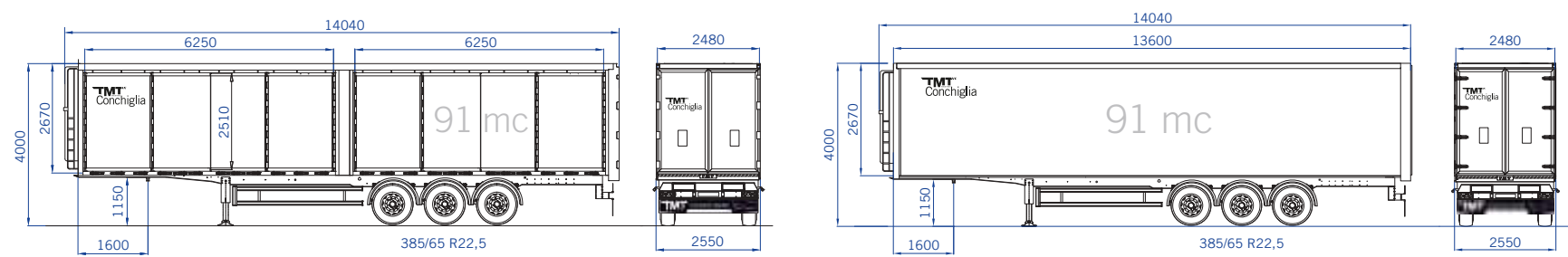

Leakproof

Semirimorchi / Moving floor

___ **Utilizzo:** ✓ Rifiuti ✓ Raccolta e conferimento CDR ✓ Plastica ✓ Carta (sia sfusi che imballati) ✓ Umido ✓ Indifferenziata ✓ Agricolo ✓ Forestale ✓ Riciclaggio ✓ 33 europallet

___ **Use:** ✓ Waste ✓ Collection and transfer RDF ✓ Plastic ✓ Paper (both loose and packed) ✓ Wet ✓ Undifferentiated ✓ Agri3cultural ✓ Forestry ✓ Recycling ✓ 33 europallets

___ **Utilisation:** ✓ Déchets ✓ Collecte et livraison des CDD ✓ Plastique ✓ Papier (en vrac et emballés) ✓ Humide ✓ Non différencié ✓ Agricole ✓ Forestier ✓ Recyclage ✓ 33 europalletes

___ **Gebrauch:** ✓ Abfälle ✓ Sammlung und Übertragung KAA ✓ Plastik ✓ Papier (unverpackt oder verschnürt) ✓ Biomüll ✓ Restmüll ✓ landwirtschaftlicher Abfall ✓ Waldabfälle ✓ Recycling ✓ 33 Europaletten



Conchiglia E110

Weight (kg)	8900
Chassis and load-bearing structure	Continuous steel chassis, aluminium box bolted to the frame
Total weight (kg)	40000 / 45000
Suspensions	Air suspensions with HALDEX, WABCO / tridem SAF, ROR, JOST, BPW
Moving floor system	Cargo Floor® System
Floor	15 alu profiles 6+9. Waterproof van
Walls	30mm aluminium alloy extruded profiles

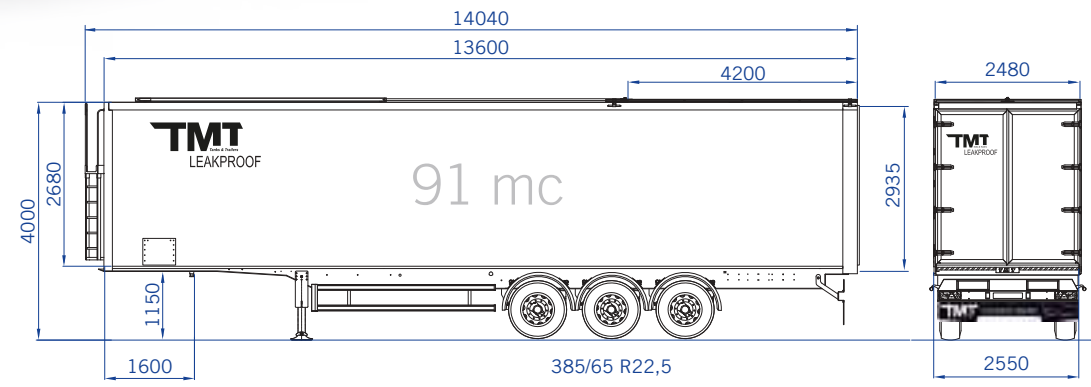

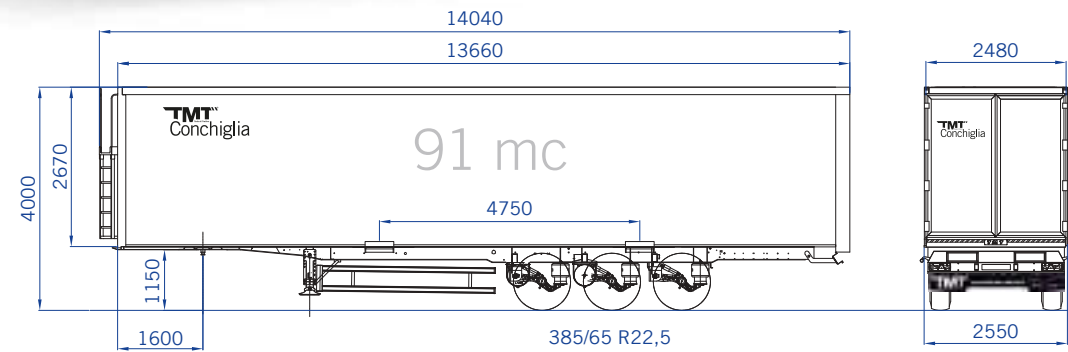

PROFILI \ PROFILES \ PROFILEN \ PLANCHERS

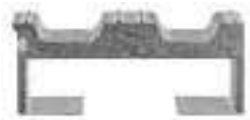

Alu profile 8-18/112mm HDI
(art. no. 30.0695)



Alu profile 8/112mm SLP ribbed
(art. no. 72.2988)
possible with SLP-channel
(art. no. 755.4525)



Alu 10/133mm Leak Proof
deckslat HD (Heavy Duty)
(art. no. 89.3497)



Non moving sideprofiles



Alu profile 10/112mm ribbed (art.
no. 25.0550)



Alu profile 6/112mm-DS ribbed (art.
no. 21.0549)



Alu profile 6/112mm ribbed (art.
no. 20.0360)

STANDARD CARGO FLOOR SYSTEM



OPTIONALS



ADR kit with fire extinguisher, PVC fire extinguisher holder, neutral folding table on the rear and 3 diamond tables per side (right, left, rear)



Underchassis toolbox double side openable 2400x950x380 thickness 1,5mm



Pressure gauge 0-10 bar connected to diaphragm for the approximation of the transported weight



Spare wheel bracket for 1/2 spare wheel



- Foldable "R" waste transport sign Italy model
- 4 wing nuts kit for greater sealing of rear doors



Wabco smart board for axle weight control



Inside aluminium protection (different dimensions)



- Foldable "A" waste transport sign German model
- Pneumatic safety lock on rear doors



All closed pallet box, 36 or 24



Compressed air quick coupling with the gun and hose in the rear part of the vehicle for cleaning the loading floor



Extra hydraulic/electric connections on the left



- KM-Counter stud
- 6 studes inox steel

OPTIONALS



Shorter semi-trailer



- IMO hooks for ferry boats
- Anchor hooks for highway-sea intermodal transport



Hydraulic Roof



Rear rubber buffers



- LED headlights
- Stainless steel bumper



- PVC toolbox 800x500x500 / 100x500x500
- 25 liters tank with soap holder



Moving Floor Remote control



6 mudguards



JOST landing gear



Inox steel toolbox 800x500x500 super mirror



Pneumatic floor sheet set



120-liters tank installed on the front of the semi-trailer

OPTIONALS



Rear door with hydraulic opening system



Openable rear roof upside frame / and liftable



Front and rear painting in a different color than the side wall / Two-tone painting / No-painting



13+13 / 18+18 / 23+23 Load retaining hooks 5 ton model



Full opened pallet box, 24



Metallic or pearly colour paint



Moving headboard



Work light kit (R, L, ant. telescopic)



Semi-waterproof moving floor with 21 slats with rear water collection tank of about 50/300 liters with side discharge



Document holder



6 chrome wheel nut covers



- Sheet with supports on one fix side
- Cut resistant sheet Carapax



Pneumatic tipping bumpers

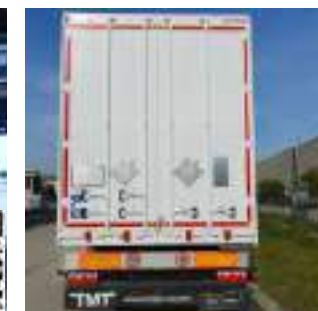

Four locking bars on rear doors



Window for load inspection